

## Valve Guide Inner Diameter

**NOTE:** Refer to the appropriate Section 303-01 for the specification.

1. **NOTE:** Valve guides tend to wear in an hourglass pattern. The ball gauge can be inserted into the combustion chamber side of the valve guide, if necessary.

Use a ball gauge to determine the inside diameter of the valve guides in 2 directions at the top, middle and bottom of the valve guide.

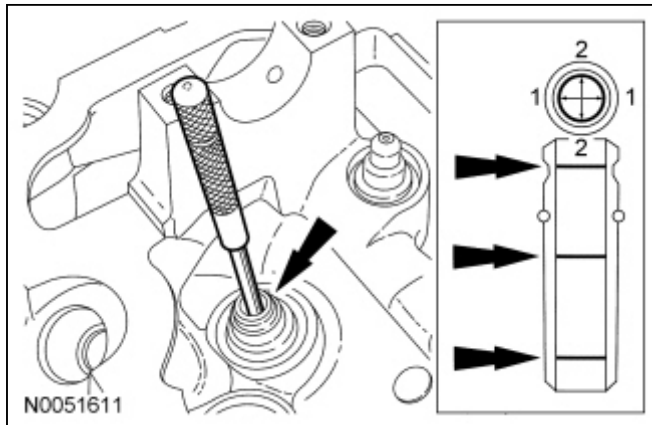

2. Measure the ball gauge with a micrometer.

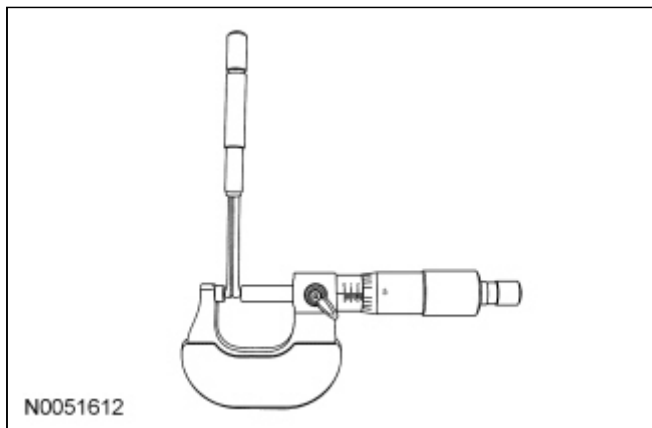

3. If the valve guide is not within specifications, install a new cylinder head assembly.

